



सत्यमेव जयते

Government of India
Ministry of Jal Shakti



A COMPREHENSIVE COMPENDIUM on

Liquid Waste Management Technologies

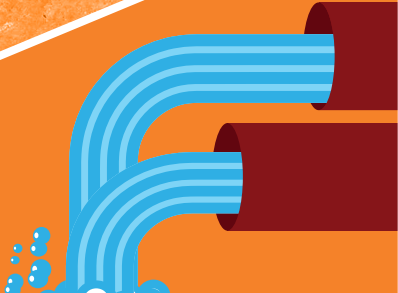



A COMPREHENSIVE COMPENDIUM **on** Liquid Waste Management Technologies

TABLE OF CONTENT

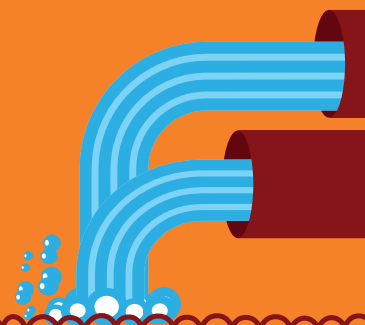

Foreword	vii
Introduction	ix
Structure and Use of Compendium	xi
Technologies Provided in Greywater Management Manual	
Waste Stabilization Pond.....	1
Constructed Wetland	4
Phytotrid	7
Decentralized Wastewater Treatment System	9
Soil Biotechnology for Sewage Treatment/Effluent Treatment.....	11
Community Leach Pit.....	13
PSA Recommended Technologies	
Johkasou	17
Absolute Vermi-filter.....	26
Other Technologies	
Community Horizontal Filter System.....	37
Community Vertical Soak Pit	41
Decision Matrix for Adoption of GWM Technology	
High Water Table Areas	46
Low Water Table Areas	48
Villages with Population More than 5000.....	50
Villages with Population Less than 5000.....	52
Case Studies	55

विनी महाजन
VINI MAHAJAN

सचिव
Secretary



सत्यमेव जयते



भारत सरकार
जल शक्ति मंत्रालय
पेयजल एवं स्वच्छता विभाग
चौथा तल, पं दीनदयाल अंत्योदय भवन
सी. जी. ओ. काम्प्लेक्स, लोधी रोड, नई दिल्ली-110003
Government of India
Ministry of Jal Shakti
Department of Drinking Water and Sanitation
4th, Floor Pt. Deendayal Antyodaya Bhawan
C. G. O. Complex, Lodhi Road, New Delhi-110003
Tel. : 24361011, 24362715, Fax : 24361207
E-mail : secydws@nic.in

Message

The Government of India launched Swachh Bharat Mission (Grameen) Phase-II in February 2020 in succession to Swachh Bharat Mission Phase I, where the prime focus is sustenance of ODF status along with management of solid and liquid wastes generated from the rural households.

It is crucial to manage the wastewater coming out from the households especially kitchen and bathroom and flowing into open drains or resulting in water-logged areas. This is known as a major cause for the waterborne diseases. The launch of Jal Jeevan Mission with a mandate to provide at least 55LPCD potable water to all Rural households has also added to our responsibility to manage the wastewater generated thereof and also in the context to planning for future; in anticipation of increased wastewater generation. Management of wastewater i.e., which contains low pathogen load is also very contextual for recycling the same for long term planning for source sustainability, and reducing the stress on the fresh water resources. This management and treatment have now also become a fundamental part of circular economy.

The Department of Drinking Water and Sanitation, Ministry of Jal Shakti, GoI in the past under the SBM(G) Phase II has released many a resource material for implementation of the Mission components for use at the village, block and other stakeholder levels. In succession to the same this **e-Compendium - “A Comprehensive Compendium on Liquid Waste Management Technologies”** has been compiled from various resources, reference materials, experiences of the States, and contribution from various stakeholders and vetted by the technological experts in the field before being launched for use by the States as a ready referencer on Liquid Waste Management Technologies.

It has a compilation of all such Liquid Waste Management Technologies enlisted in Swachh Bharat Mission (Grameen) Phase-II Operational Guidelines, Greywater Management Manual and Technologies approved by PSA Committee along with relevant and successful Case studies received from State/UTs.

All ground level implementers and various stakeholders may refer to it as comprehensive knowledge bank on Liquid Waste Management. We hope this e-Compendium will facilitate informed decision-making and strategizing in designing Liquid Waste Management systems.

Furthermore, the State/ UTs are requested to share the enhanced implementation experiences and successful Liquid Waste Management (LWM) Case studies to be incorporated in the future edition of the **e-Compendium- II**.

(VINI MAHAJAN)

INTRODUCTION

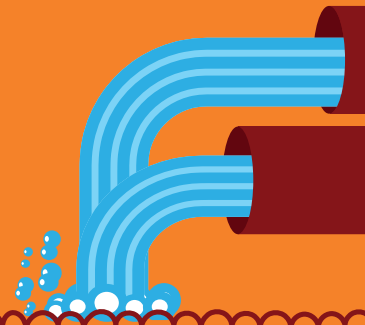

Background and Target Audience

Appropriate and adequate liquid waste management (LWM) solutions are crucial for the protection of human and environmental health. In recent years there has been an increase in number of liquid waste management innovations, appropriate for varied geographical and climatic conditions, and a stronger sector focus on liquid waste management service chain (from collection and conveyance to the final treatment and safe disposal or reuse). Building on these developments, the Compendium of liquid waste management Technologies provides a comprehensive, structured and user-friendly manual and planning guide for liquid waste management solutions. It serves as a systematic overview of existing and emerging liquid waste management technologies appropriate for use in rural India as per geographical conditions.

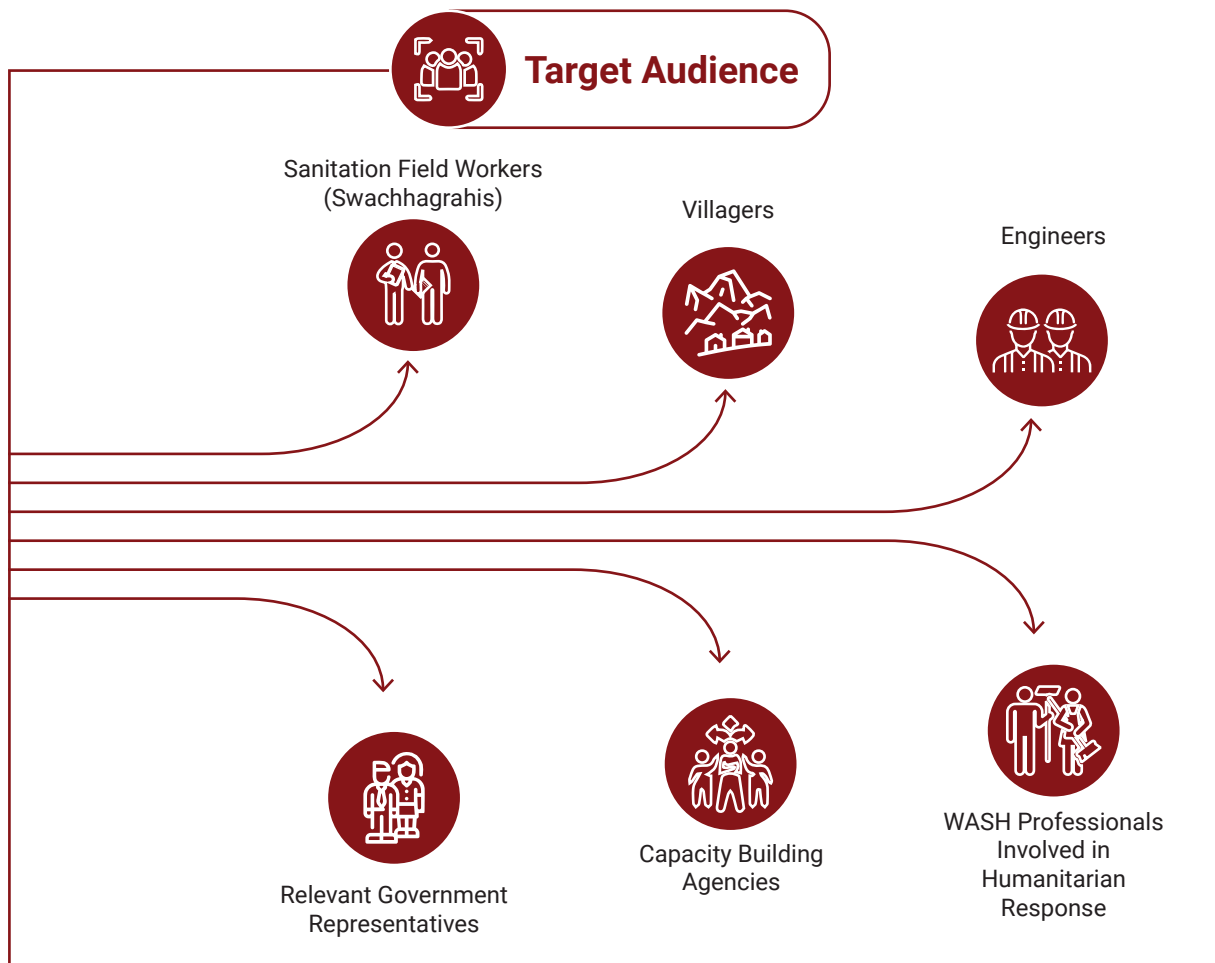

The publication can be seen as a starting point to access relevant information for the design of suitable liquid Waste management system solutions.

The Compendium of liquid waste management technologies is primarily a capacity building tool and reference book. In addition, it supports and enables decision-making by providing the necessary framework for designing a liquid waste management system, by giving concise information on key decision criteria for each technology, facilitating the combination of technologies to come up with full liquid waste management system

solutions and linking it to relevant cross-cutting issues. The users are also directed to additional information through further references in the publication and tools (case studies, pictures, working principle and comparative sheet). This publication is not a detailed design manual, rather it is a user-friendly compendium meant to facilitate informed decision-making in designing liquid waste management systems.



STRUCTURE AND USE OF COMPENDIUM

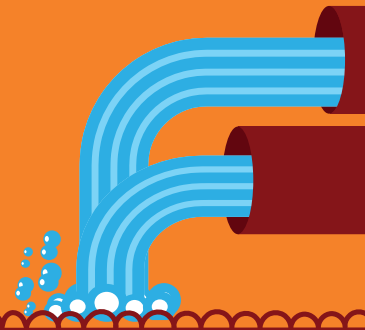

The structure of this compendium is to provide brief knowledge about the technological interventions required for the Liquid Waste Management to the targeted audience. Eventually, the user should be able to develop one or several system configurations to present to the community of the intervention area. Following the community's suggestions, the compendium can then be used to re-evaluate and redesign the systems accordingly. The compendium is only one document in the field to facilitate informed decision-making on the part of different stakeholders involved in improving environmental sanitation services, and should be used in conjunction with other available publications and tools.





TECHNOLOGIES PROVIDED IN GREYWATER MANAGEMENT MANUAL





WASTE STABILIZATION POND

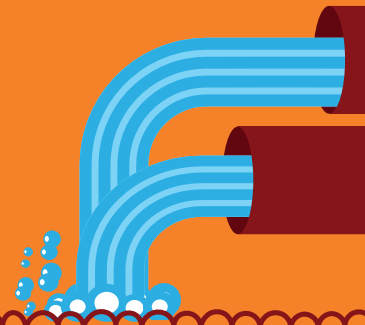

1.1 Introduction

Waste stabilization is a conventional technology in which a series of ponds is developed for the treatment of wastewater through natural microbial processes.

However, the number of ponds and their sizing depends on the quality and quantity of the influent. An average reduction of waste matter ranging from 80 to 90 per cent of biochemical oxygen demand (BOD) at a loading rate of 150 to 325 kg/ha/day.

1.2 Feasibility

Geographic Requirement



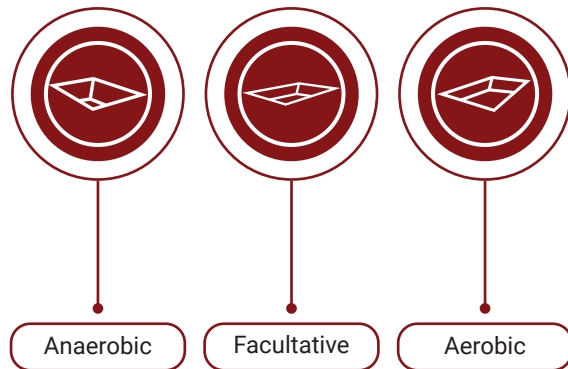

Site Identification: The technology of waste stabilization pond can be taken up in all types of terrain. Space requirement appropriate to the quantity and characteristics of liquid waste to be treated is the most important prerequisite. Availability of continuous space due to undulations could be the most challenging part in hilly areas making this technology unfit for hilly areas.

Three Ponds Adopted in this Technology



Areas with cold climate may not be suitable for this technology as effective microbial processes may not take place for waste treatment.



-  The site should not be prone to flooding at any time of the year.
-  The site should be at least 100 m away from residential areas.
-  This technology may become cost-intensive in the areas with black cotton and clay soil as it may need a permanent lining to prevent the collapsing of the ponds
-  In homogeneous soils, no well should be within a distance of 15 m from the pond and should preferably be at a distance of 50 m.
-  It is not possible to indicate the safe distance between a waste stabilization pond and a ground water source located in areas of fissured rock formation, limestone or gravel deposits; in such situations, to avoid any health hazards or other undesirable conditions, a critical evaluation of ground water pollution should be made before selecting the site.

Soil: Waste Stabilization Ponds (WSPs) are preferred in relatively impervious soils to avoid percolation. If excessive seepage loads (greater than 10 per cent) are anticipated, the pond bed should be lined with 300 mm puddle clay, polythene sheeting or any appropriate material.

1.3 Technical Details

Components of WSP

Pond type	Description	Depth (m)	HRT (days)
Anaerobic Pond	The decomposition and microbial action in this pond take place in absence of oxygen. Majorly contributes in BOD reduction. Can be omitted if BOD is less than 100 mg/l	2-3	1-2
Facultative Pond	The lower section of the pond provides an anaerobic environment while the decomposition in the upper section is an aerobic activity.	1.2-1.8	3-6
Aerobic Pond	This is a shallow pond where the microbial action takes place in the presence of oxygen and sunlight. The primary function of a maturation pond is to remove pathogens.	1.2-1.8	3-5

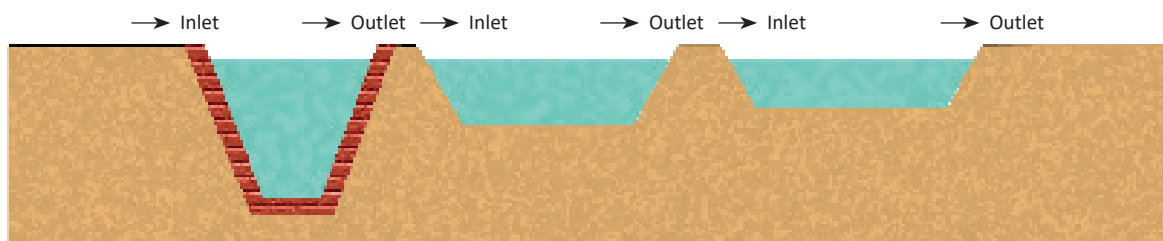

1.4 Financial Details

This technology is found suitable for liquid waste management. The details for cost of construction & installation, area and power requirement, etc. are mentioned below:

Sr. No.	Technical & Financial Details	
1.	Technology Name	Waste Stabilization Pond
2.	Technical Details	
	A. Area Requirement	For 211 KLD Area Requirement -: 2050 M ²
	B. Power Requirement	Not Required (Nr)
	C. Water Requirement	NR
	D. Manpower Requirement (Skilled, Semi-skilled, Unskilled)	1 Unskilled
3.	Cost Information	
	a. CapEx (INR Lakhs)	INR 16,58,076 /- FOR 211 KLD
	b. OpEx (INR Lakhs)	INR 9,650 /- FOR 211 KLD

2 CONSTRUCTED WETLAND

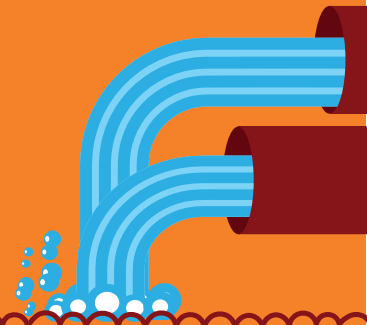

2.1 Introduction

Constructed Wetlands (CWs) are man-made systems in which wastewater treatment is achieved through natural processes involving soil, vegetation, and microbial communities.

Based on its flow Pattern, Constructed Wetland can be Classified into:



Free Water Surface

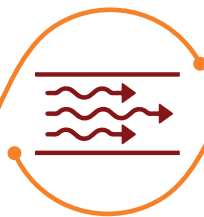

Horizontal Flow



Vertical Flow



2.2 Feasibility

Geographic Requirement

- The site should not be prone to flooding at any time of the year.
- The site should be located near the disposal or reuse point.
- The wetland should be accessible from all sides for O&M purpose

2.3 Technical Details

Components of Constructed Wetland

Based on the characteristics of the liquid waste, the following pre-treatment and vegetation options should be considered in the design:

Grease Trap Chamber: To remove grease in the form of scum that floats over the wastewater as it settles into a chamber, a grease trap chamber is required.

Screen Chamber: A vertical bar screen is usually provided in a chamber to restrict the entry into the subsequent treatment units of unwanted materials, such as plastics and dry leaves.

Grit Chamber: As the incoming water rests on a chamber, the heavy inorganic particles are separated from the liquid and settle at the bottom of the chamber. The supernatant liquid then flows into the subsequent treatment unit.

Sedimentation Tank: It is important to allow settlement of influents through some primary treatment.

Liner: The wetland unit is provided with a non-permeable liner to avoid leaching of effluents.

Vegetation: Any native plant with deep, wide roots that can grow in a wet, nutrient-rich environment is appropriate. Phragmites, australis (reed) is a common choice because it forms horizontal rhizomes that penetrate the entire filter depth of the filter bed.

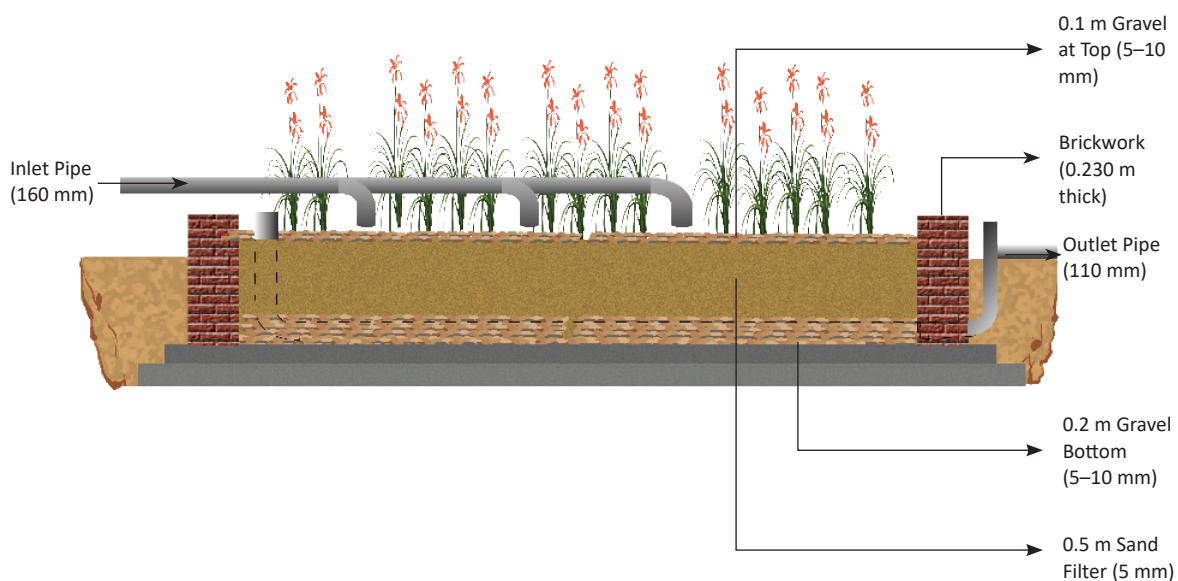

2.4 Financial Details

This technology is found suitable for liquid waste management. The details for cost of construction and installation, area and power requirement, etc. are mentioned below:

Sr. No.	Technical & Financial Details	
1.	Technology Name	Waste Stabalization Pond
2.	Technical Details	
	a. Area Requirement	Area Requirement: 800 M2 For 211 KLD
	b. Power Requirement	NR
	c. Water Requirement	NR
	d. Manpower Requirement (Skilled, Semi-skilled, Unskilled)	1 Skilled
3.	Cost Information	
	a. CapEx (INR Lakhs)	INR 36,38,113 /- FOR 211 KLD
	b. OpEx (INR Lakhs)	INR 11,500 /-

3 PHYTORID

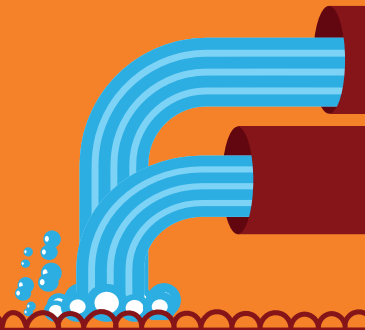

3.1 Introduction

Phytorid is a Subsurface Mixed Flow Constructed Wetland System (SSFCW) developed and patented by the National Environmental Engineering Research Institute (NEERI), Nagpur.

3.2 Feasibility

Geographical Requirement

Site Identification: The technology is not terrain- specific and can be adopted in any terrain. However, the site should not be prone to flooding at any time of the year and should be at least 500 m away from residential areas. The space requirement is 129 sq. m. for 100 KLD and should be located near the disposal or reuse point.



3.3 Technical Details

Components of Phytorid

Intake Well: An intake well is used to feed the wastewater as generally the invert level as well as drains are below ground level.

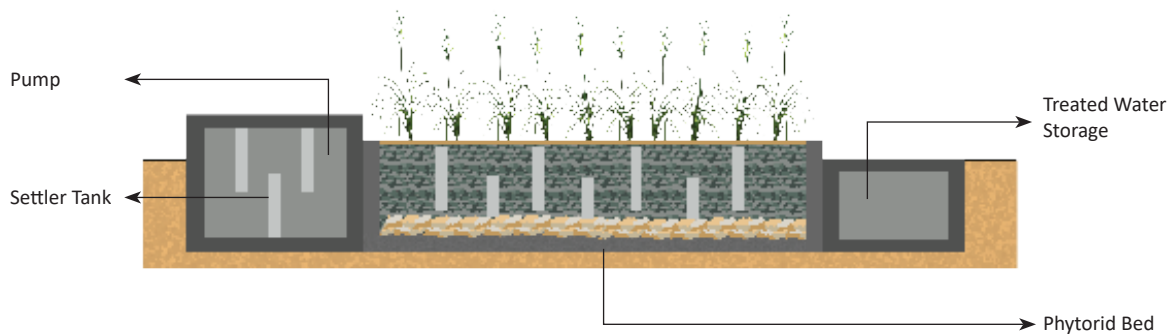

Screen Chamber: A bar screen is provided to block floating materials such as dry leaves, plastic wares and sanitary napkins, and prevent them from entering the settling tank. The gaps between the bars may vary between 10 and 25 mm.

Settler Tank: The sewage from the bar screen chamber is fed by gravity to the settling tanks. Its main function is to act as a buffer. The solid then gets settled in this tank and is continuously digested, thereby reducing the frequency with which tanks have to be cleaned. This tank is a covered one with manholes and baffles arrangement. Wastewater is directly fed to the phytorid bed.

Phytorid Bed: Phytorid bed is the heart of the treatment system. The bulk of the treatment happens here, with microbes/bacteria employed for the process and the nutrients, like nitrates and phosphates, uptake by the plants. The gravel acts as a media for the microbe growth.

3.4 Financial Details

This technology is found suitable for liquid waste management. The details for Cost of construction & installation, Area & Power requirement etc. are mentioned below:

Sr. No.	Technical & Financial Details	
1.	Technology Name	Waste Stabalization Pond
2.	Technical Details	
	a. Area Requirement	For 100 KLD Area Requirement: 120 M2
	b. Power Requirement	NR
	c. Water Requirement	NR
	d. Manpower Requirement (Skilled, Semi-skilled, Unskilled)	NR
3.	Cost Information	
	a. CapEx(INR Lakhs)	INR 51,961 FOR 1KLD
	b. OpEx (INR Lakhs)	INR 15,000 /-



DECENTRALIZED WASTEWATER TREATMENT SYSTEM

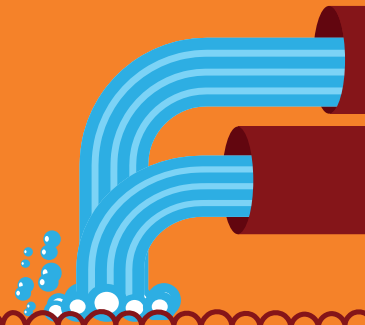

4.1 Introduction

A Decentralized Wastewater Treatment System (DEWATS) is a robust nature-based technology that uses a combination of different treatment modules and is used to achieve the desired level of treatment. To treat the wastewater, natural bacteria and plants are used and gravity is also taken into account during the planning process.

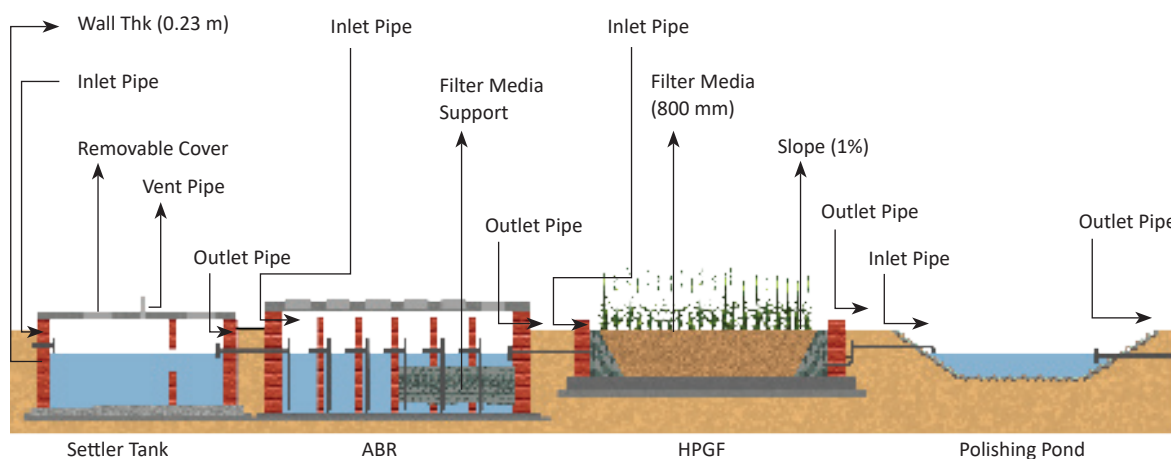

4.2 Feasibility

Geographical Requirement

This technology basically consists of various units in a series. The selection of units, their retention time and sizes as well as the construction methodology can be customized as per local conditions, as well as the quality and quantity of influents.

Location:

- The technology is not terrain-specific and can be adopted anywhere.
- But the site should not be prone to flooding at any time of the year.
- The site should be located near the disposal or reuse point

DEWATS is suitable for treating domestic wastewater only and is not advised for treating industrial wastewater.

4.3 Technical Details

Components of DEWATS

Settler: A two-chambered sedimentation tank which provides retention time for settlement of suspended solids in the influent.

Anaerobic Baffled Reactor (ABR): In this part of the process anaerobic degradation of suspended and dissolved solids occurs through the mixing of fresh wastewater with an active sludge blanket. The reactor is an RCC/masonry tank with a number of compartments separated by baffles. Wastewater enters the chamber from an elevated pipeline. As the height of the water column increases, water flows to the next compartment. Thus, water travels through a series of chambers with a certain up-flow velocity that helps the organic content in the wastewater to settle at the bottom of each chamber while the wastewater moves forward for further treatment. It should be noted that greywater is low in solid content and so the provision of ABR should be adopted only where there is a high organic load.

This is a tertiary treatment unit, which helps in removing the odor and discoloring on in the wastewater. In this treatment module, plants and gravel media capable of up taking and treating organic matter and nutrients are used. The nutrients in the influent are consumed by the plants in the filter bed while the organics are decomposed primarily under anaerobic conditions. Plant roots allow the transport of oxygen from the air to a certain level creating limited aerobic conditions near the root zone.

Polishing Ponds: Followed by the planted gravel filter, a polishing pond is provided, which is an open shallow water body. Treated water is allowed to stay in this pond with designated retention times. The main purpose of this pond is oxygen enrichment and elimination of pathogen germs through natural solar radiation.

4.4 Financial Details

This technology is found suitable for liquid waste management. The details for cost of construction and installation, area and power requirement, etc. are mentioned below:

Sr. No.	Technical & Financial Details	
1.	Technology Name	DEWATS
2.	Technical Details	
	a. Area Requirement	For 211 KLD Area Requirement -: 350 M ²
	b. Power Requirement	NR
	c. Water Requirement	NR
	d. Manpower Requirement (Skilled, Semi-skilled, Unskilled)	NR
3.	Cost Information	
	a. CapEx (INR Lakhs)	INR 50,27,999 /- FOR 211 KLD
	b. OpEx (INR Lakhs)	INR 10,000 /-



SOIL BIOTECHNOLOGY FOR SEWAGE TREATMENT / EFFLUENT TREATMENT

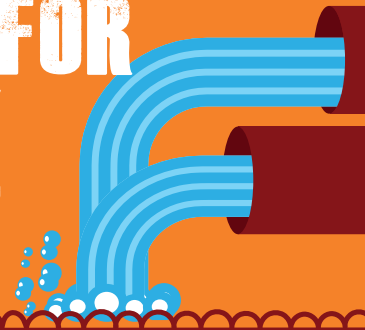

5.1 Introduction

This technology has been developed by IIT, Mumbai. SBT engages three fundamental process of nature – photosynthesis, respiration and mineral weathering. This is achieved by soil microorganisms, which are regulated by soil microorganisms (geophagus earthworms).

Primary and secondary treatments are achieved in the Soil Biotechnology (SBT). The organic and inorganic matter in wastewater is consumed and converted into useful by-products, which simultaneously produces water of desirable quality. SBT thus removes BOD, COD, ammonia, nitrogen, nitrate nitrogen, suspended solids bacteria, colour and odour. The SBT is ideal for treating wastewater less than 5 MLD.



5.2 Feasibility

Geographical Requirement

SBT can be designed to treat any type of wastewater provided the wastewater is not saline (i.e., having total dissolved solids (TDS) = 1,000 mg/L typically) and as long as the water is not toxic to microorganisms. SBT process requires temperature of 20–45 degree Celsius (in low /very low temperature, a greenhouse infrastructure appropriate for the local conditions can house the SBT plant). The process can also work at high ambient temperatures.

5.3 Technical Details

Components of SBT

- Results in rejuvenation on/creation on of soil.
- Can be utilized for all sorts of organic and inorganic molecules present in the effluents.
- Does not require electricity and chemical (electricity requirement only for pumping).
- Generates bio-energy.
- Requires little space area as per requirement per person (100 Litre/day) is. 0.021 M.²
- Natural process-based wastewater treatment.
- Does not involve mechanical aeration, yet enough oxygen produced in the bioreactor.
- Does not generate sludge, smell or odour.
- Process can be run on both batch and continuous modes.
- Overall time operation (wetting cycle) is 6–7 hours.
- Capable of handling shock load of 50 per cent over or under design load for a few days automatically.
- Land area requirement ranges from 1,500 to 2,500 sqm per MLD.
- Minimal energy consumption (40–50 kWh per MLD to pump the wastewater for distribution over reactor bed).
- O&M cost of SBT plant costs Rs. 2–4 per KLD per annum (Rs. 4,000 per MLD per annum).
- Does not require skilled labour for O&M.

The SBT plant requires minimal O&M periodically that includes cleaning of pipes and scraping of the top surface to remove these led suspended particles. The microbial culture is tested and recommended to be changed every 8–10 years. The system does not require highly skilled labour.

Easy operation is the main feature of SBT. To ensure smooth functioning of the system, the availability of adequate water in the raw water tank needs to be checked. The system will automatically shut off if the level of water falls below a minimum safety threshold in the raw water tank.

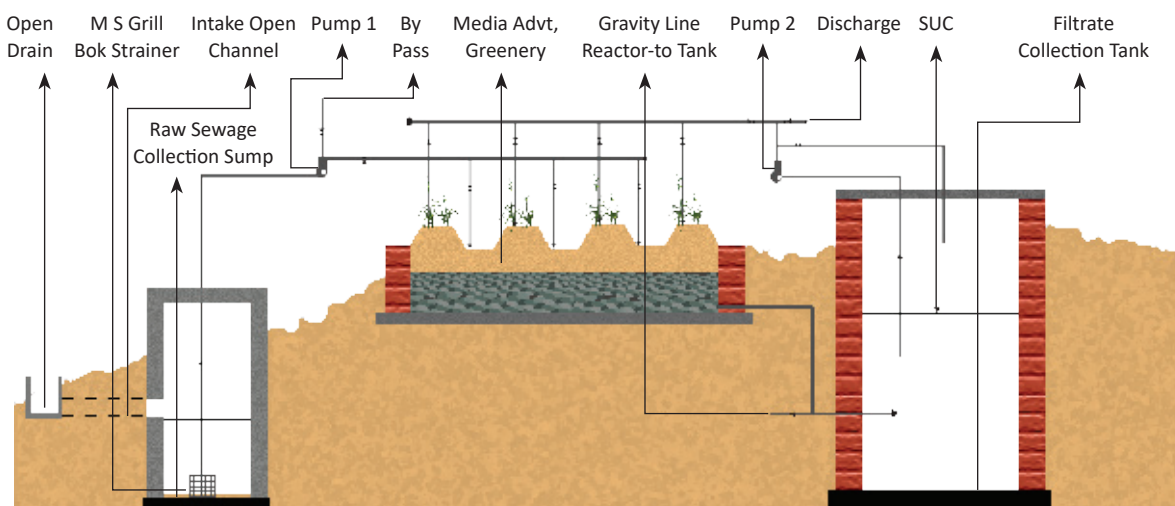



COMMUNITY LEACH PIT

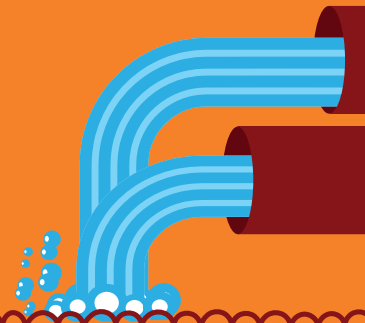

6.1 Introduction

A community leach pit is an extended version of a household leach pit where multiple houses can be connected to a single pit.

6.2 Feasibility Details

Geographical Requirement

This option is adopted in areas with space constraints or non-availability permeable soil in the vicinity of the individual household. Areas where higher amount of greywater is generated, such as schools, restaurants, community stand ponds, etc. should adopt the community leach pit based on the volume of greywater generated. Bottom of the pit should be at least 2 m above the water table site selection for a community leach pit should be based on the ground slope and optimal length of connecting pipe.

6.3 Technical Details

Components of Community Leach Pit

Pit Lining: A community leach pit is lined with honeycomb brick masonry following working principles similar to those applied to household leach pits. In the case of a community-level leach pit, the brick masonry lining should be of 230 mm thickness and for construction on 1:6 mortars should be used.

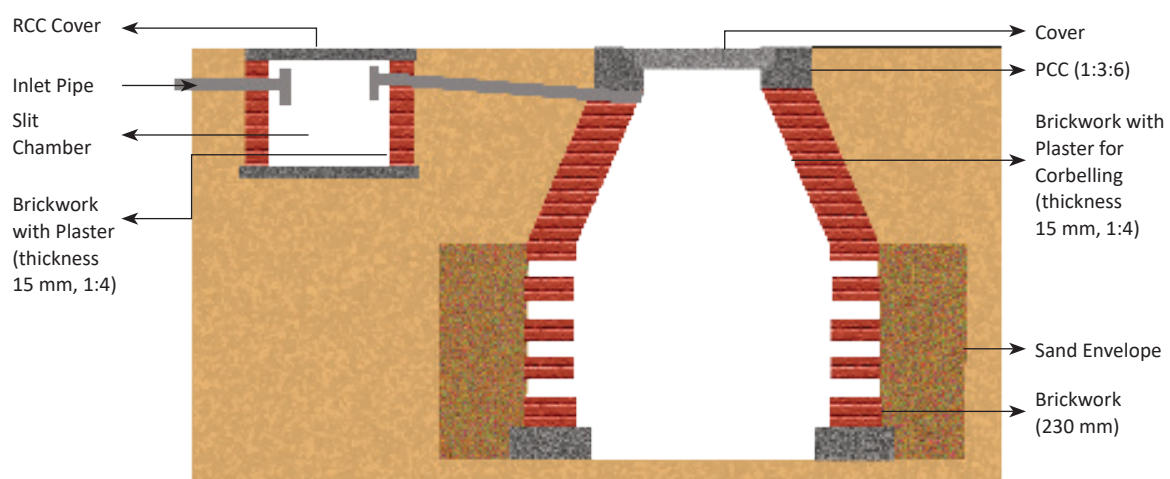

Silt Chamber: The silt chamber reduces the silt and traps the oil and grease in the greywater before it enters the leach pit.

Plumbing Arrangements: All the households connecting to the community leach pit should have nahani trap installed at the point where the greywater is generated.

Cover: Similar to household-level leach pits, these community pits are also covered with RCC covers, Ferro-cement slabs.

6.4 Financial Details

This technology is found suitable for greywater management. The details for cost of construction and installation, area and power requirement, etc. are mentioned below:

Sr. No.	Technical & Financial Details	
1.	Technology Name	Community Leach Pit
2.	Technical Details	
	a. Area Requirement	1.25M*0.65M*0.65M (L*B*H)
	b. Power Requirement	NR
	c. Water Requirement	NR
	d. Manpower Requirement (Skilled, Semi-skilled, Unskilled)	NR
3.	Cost Information	
	a. CapEx (Rs. lakhs)	Rs. 22,776 /-
	b. OpEx (Rs. lakhs)	Desludging to be Done Once every 56 Years

PSA RECOMMENDED TECHNOLOGIES



7

JOHKASOU

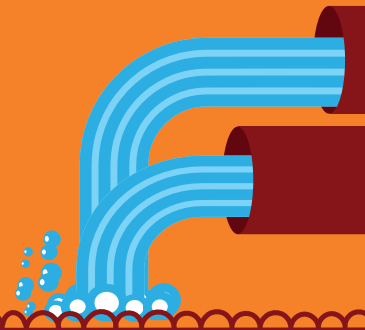

7.1 Introduction

Johkasou product is domestic wastewater treatment system. This is made up of 100 per cent Fibre Reinforced Plastic (FRP) and it is a combination of aerobic and anaerobic treatment on wastewater at one time, with entire treatment housed in a single FRP capsule.



The system flows the A-A-A (Anaerobic, Aerobic, Anaerobic) operational process ensures continuous and simultaneous Nitrification and Denitrification.

There are three models of Johkasou-STP, but for rural context AI-type is advisable for GWM. Because it is most flexible and economical model as compared to other models.

7.2 Feasibility

Geographic Requirement

Johkasou is a packaged wastewater treatment system that can be installed in any terrain and all built environments, wherever the wastewater needs to be treated and made fit to discharge into the open areas, drains, ponds, or to use for non-potable water usage.

Appropriateness of Technology

Johkasou packaged wastewater treatment system having three different models contributing in liquid waste management among them AI-type model is suitable for GWM significantly in to the rural area offering opportunities for wastewater recycling & reuse.

- Contributes to liquid waste management in:
 - ◊ Building
 - ◊ Institutions
 - ◊ Villages
- Reduces dependency on freshwater source by treating and recycling wastewater
- Easy to maintain, high-performance treatment system and removes nutrients efficiently
- Contains a spacious separation box to separate and store the sludge, which can be drawn at the time of maintenance
- Requires O&M once in 6 months
- Consumes low energy
- Lesser operation cost and highly modular & scalable
- Long plant life

7.3 Technical Details

Design and Process Description

The design and process description of each component of the system is mentioned below:

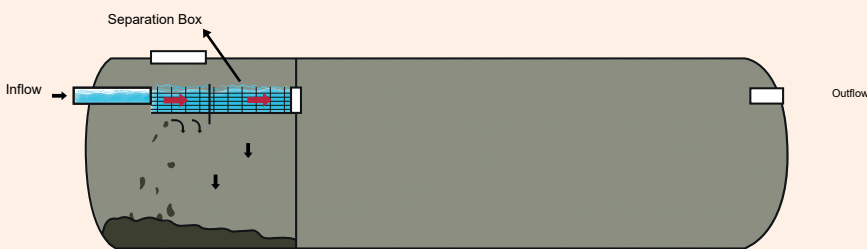
Sedimentation and Separation Chamber	
Equipment	Separation Box
Illustration	
Function	Separating solid waste and liquid waste based on their gravity. Solid waste which has bigger density than water will be settled in the bottom of sedimentation chamber. On the other hand, lower density materials float and stay here.

<p>Components</p>	<div style="text-align: center;">  </div> <p style="text-align: center;">Sedimentation Chamber Separation Box</p> <p>Separation box</p> <ul style="list-style-type: none"> ● To separate solid waste and water ● To collect large object in wastewater
-------------------	------------------------------------------------------------------------------------------------------------------------------------------------------------------------------------------------------------------------------------------------------------------------------------------------------------------------------------------------------------------------------

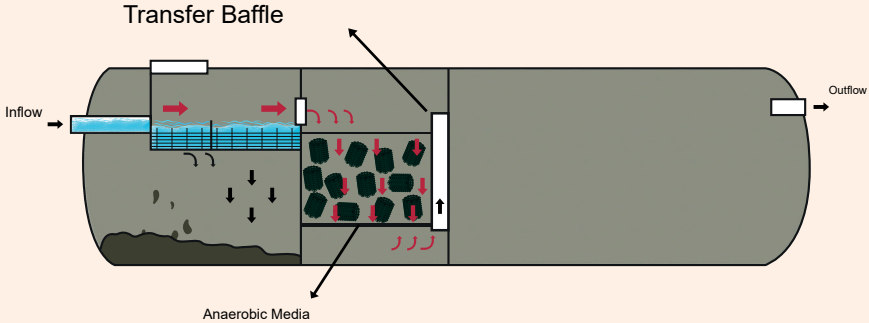
<p>Equipment</p> <hr/> <p>Illustration</p> <hr/> <p>Function</p>	<p style="text-align: center;">Anaerobic Contact Media Chamber</p> <hr/> <p>Anaerobic Media and Transfer Baffle</p> <div style="text-align: center;">  </div> <p>Anaerobic media inside of anaerobic contact media chamber is the place where Anaerobic bacteria is growing up to decompose organic material contained in domestic wastewater resulting more simple organic content.</p> <p>To store excess sludge at the bottom and scum at surface of the water.</p> <p>Small SS is caught and stored by anaerobic media to reduce a load of moving bed chamber.</p> <p>Almost of NO_2 and NO_3 are reduced to N_2 gas by denitrification bacteria which is settled in anaerobic media.</p>
------------------------------------------------------------------	------------------------------------------------------------------------------------------------------------------------------------------------------------------------------------------------------------------------------------------------------------------------------------------------------------------------------------------------------------------------------------------------------------------------------------------------------------------------------------------------------------------------------------------------------------------------------------------------------------------------------------------------------------------------------------------------------------------------------------------------------------------------------------------------------------------------------------------------------

Components



Anaerobic media (BA/BAE/BJ/BJE)



Anaerobic media (AI/AIJ)

Anaerobic Media

- The place where anaerobic microorganism is growing up.
- Anaerobic media catches SS and stores it inside.

Transfer Baffle

- As wastewater channel
- Desludging channel of anaerobic chamber

Equipment

Moving Bed Media, Diffuser, Media Screen/Trap

Illustration

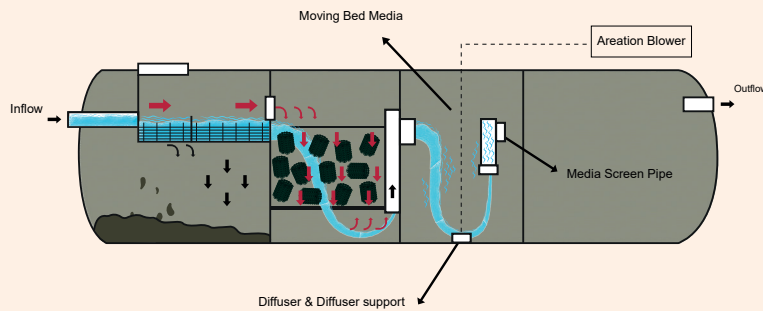

Diffuser & Diffuser Support

Function

Moving bed chamber consist of contact media called “moving bed media”, and aerobic microorganism is growing up inside of it. Moving bed chamber filled by moving bed media with 30–50 per cent of the volume. Aerobic microorganism will decompose organic material from anaerobic chamber.

This aerobic microorganism consumption oxygen supplied by blower distributed through pipe line and diffuser located in the bottom of moving bed chamber. By generating oxygen in this chamber, moving bed media circulate in this chamber. Organic material is contacted to microorganism inside of moving bed media due to this circulation. In this process, organic material decomposition process will occur, and majority of the BOD, COD and other parameters level is decreased with in their limits

Denitrification process occurs: NO_3 (Nitrate) \rightarrow NO_2 (Nitrite) \rightarrow NO (Nitric oxide) \rightarrow N_2O (Nitrous oxide) \rightarrow N_2 (Nitrogen)

Components

Moving Bed Media

- The Place where aerobic microorganism is growing up.

Diffuser

- Air diffuser is a device that is designed to provide uniform air flow throughout a room.
- It works to increase the efficiency of air-conditioning

Media Screen/Trap

- To prevent the media from transferring to the next chamber.

Blower

- It provides air to the moving bed chamber. It works for 24 hr.



Sedimentation Chamber

Equipment

Measuring Box, Circulation Process

Illustration

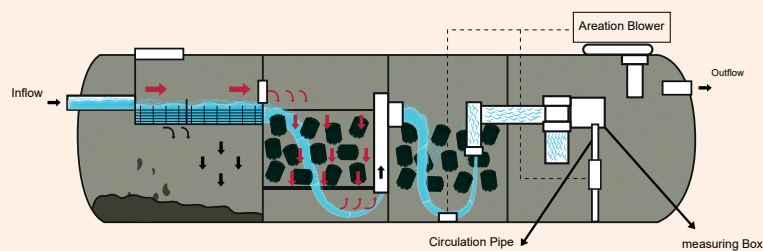

Function

Sedimentation chamber is the place to settle sludge generated by aeration process, and treated water flows into disinfection chamber. Sludge accumulated in the bottom will be transferred to sedimentation and separation chamber, which is called circulation because besides returning sludge into the sedimentation separation chamber, it also helps the denitrification process.

Components

Measuring Box

- Circulation flow control
- *Circulated water quantity is controlled by adjustment of air quantity for air lift pump, and it can be checked at V-notch weir.



Circulation Pipe

V notch

View of Sedimentation Chamber

Air Valve for Air lift pump

Disinfection Chamber

Equipment

Disinfection Device

Illustration

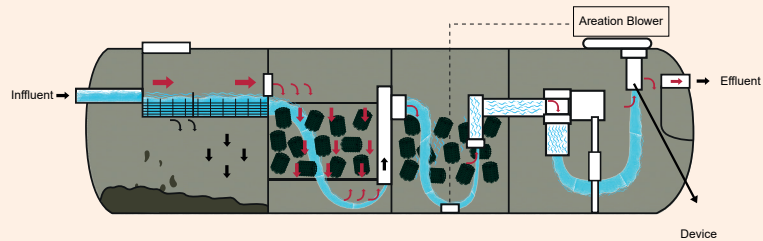

Function

Microorganisms consisting in the treated water are disinfected by chlorine in the device before discharged into the environment.

Components



Chlorine tube

Disinfection tank
Disinfection stage
V-notch

View of Sedimentation Chamber

Disinfection Device

Disinfection device consists of V-notch, disinfection stage and disinfection tank

- Treated water comes into the disinfection stage over a V-notch.
- Chlorine tablet which is in the chlorine tube is dissolved with the treated water.
- The treated water containing dissolved chlorine drops into the disinfection tank.
- In the disinfection tank, microorganisms are killed by chlorine.

7.4 Operational Details

The operational details of the technology is mentioned below:

Process Flow Diagram

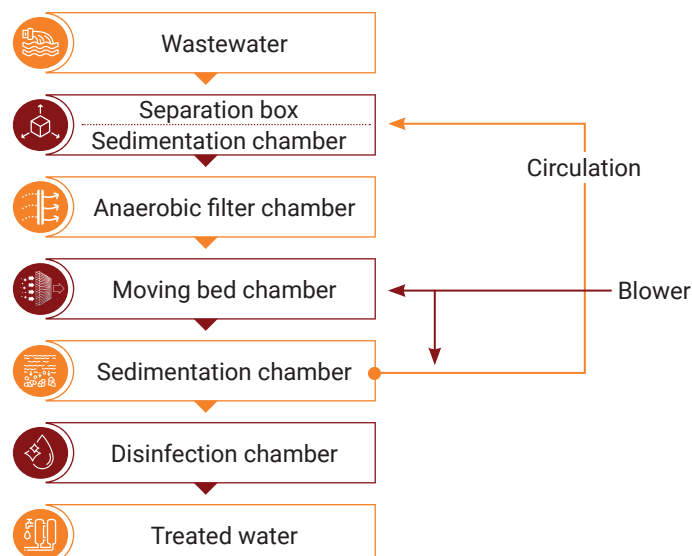

Sedimentation and separation chamber collects domestic wastewater. It also has function to separate solid wastes from liquid waste based on their gravity.

Wastewater then flows into anaerobic media contact chamber from sedimentation and separation chamber. It contains organic material which is decomposed by anaerobic microorganism.

On the other hand, nitrite and nitrate contained in the circulated water are converted into N₂ gas by denitrification microorganisms.

Anaerobic reaction is shown as follow:



Anaerobic process treatment water flows into moving bed chamber. Organic material contained wastewater is decomposed by aerobic microorganism, and becomes simpler product. In this case the organic waste material is used for development of new cells (protoplasm) and converted to other materials such as carbon dioxide, water, and ammonia.

Aerobic reaction shown as follow:

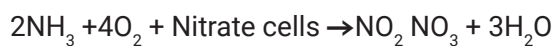
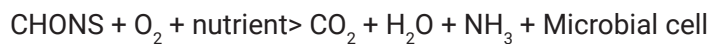

Results of aerobic biological processes will also produce sludge which is suspended from treated water.

Sedimentation chamber has function as place of settled sludge which is resulted by biological processes in moving bed chamber. Settled sludge will be transferred to sedimentation and separation chamber. Concurrently NO₂ and NO₃ are transferred to its chamber.

Note: Without sedimentation chamber sludge will flow out resulting turbid water detected as total suspended solid and COD.

Disinfectant chamber serves as a place to put chlorine / disinfectant as a sterilization agent pathogenic microorganisms in the waste are treated before discharged into the environment.

7.5 Financial Details

This technology is found suitable for liquid waste management. The details for cost of construction and installation, area and power requirement, etc. are mentioned below:

Sr. No.	Technical & Financial Details	
1.	Technology Name	Johkasou
2.	Technical Details	
	a. Area Requirement	For 1 KLD Area Requirement: 2 Square Metre
		For 50 KLD Area Requirement: 36 Square Metre

Sr. No.	Technical & Financial Details	
	b. Power Requirement	For 1 KLD Power Requirement: 41 KW For 50 KLD Power Requirement: 400 KW
	c. Water Requirement	NR
	d. Manpower Requirement (Skilled, Semi-skilled, Unskilled)	Unskilled
3.	Cost Information	
	a. CapEx (Rs. lakhs)	Rs. 1,65,000/- FOR 1 KLD Rs. 19,50,000/- FOR 50 KLD
	b. OpEx (Rs. lakhs)	Rs. 40,000/- FOR 1 KLD (Per month or Annum??) Rs. 3,60,000/- FOR 50 KLD (Per Month or Annum?)



ABSOLUTE VERMI-FILTER

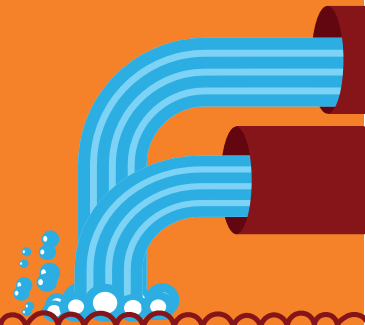

8.1 Introduction

The conventional principle for treating organic matter or pollutants in wastewater involves microbes and their feeding with oxygen. Bio-filtration involves no mechanical aeration. It is based on treating of wastewater using organic and inorganic media and attached growth microbes. The bio-filtration process makes use of vermi-culture as their one of the key components in reducing organic matter as well as nutrients from wastewater effectively. Vermi-culture in combination of natural and inorganic media gravity filtration serves the treatment of wastewater to re-usable standards. Vermi-culture is a completely GREEN process having multiple benefits in terms of operation, handling and maintenance.



8.2 Feasibility

Geographic Requirement

- The site should not be prone to flooding throughout the year. Modular systems are available in order to tackle flooding situations.

- The site can be located near the disposal or reuse point or pumping option may be utilized in other cases.
- The bio-filter should be accessible from all sides for O&M purpose in general conditions. But in compact system two sides of the same can be covered and yet O&M can be carried out easily.
- It is most suitably designed to be implemented in rural areas other than urban.
- The land requirement is very low as compared to other GWM technologies, i.e., 0.75 m²/m³ of wastewater. Modular skid based and large civil based installations are available suiting the requirement as per geography. The biofiltration technology performs equally in terms of change in atmospheric temperature. (-2 degree to 48 degree C)

Appropriateness of Technology

- These systems are able to tolerate fluctuations in hydraulic and organic load.
- High possibility of resource recovery.
- No mosquitoes and odour nuisance.
- Self-sufficiency, ecological balance and economic viability is greater.
- Easy to operate & maintain, reliable performance.
- No chlorinated by-products.
- Sludge generated is very rich in fertilizer properties. The same can be used as manure.

8.3 Technical Details

Design and Process Description

The bio-filter works on the principle of vermi-filtration where specially bred worm species and a mix of bacteria act on the suspended and dissolved solids in the raw sewage and biologically degrade in an environmentally safe manner. This is a continuous process; therefore, the treated sewage keeps flowing through an inclined drain at the floor of the bio-filter into the treated water tank which can be used for further treatment or irrigation/horticulture etc. The criteria for designing the bio-filter are as follows:

- Pre-treatment of liquid waste will be required for organic loads above 500 mg BOD/l.
- Settler/sedimentation tank are not required and are replaced by choke free physical micron filtration for silt removal.
- The maximum organic loading for bio-filter should be 350 mg/l BOD, 500 mg/l COD, 450 mg/l TS.
- Graded media should be provided as per drawing and should be checked for disintegration.
- There should be provisions for uniform distribution of liquid waste to the surface.

Process Description

Equipment

Wastewater Diverting Channel with Bar Screen

Illustration

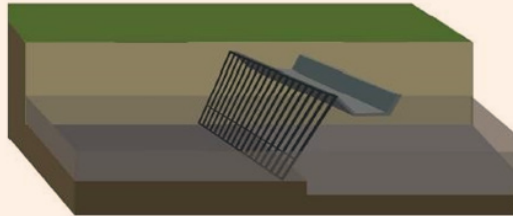

Function

Manual bar screen to be installed in nallahs or drains or channels just before they are about to enter liquid waste treatment system. These screens allow removing major large size particles and silts up to 6mm size manually by simple gravity screening.

Components



Bar Screen

Channel

Manual Bar Screen

- To separate solid waste and water
- To collect large object in wastewater

Process Description

Equipment

Strainer or Silt Removal System

Illustration

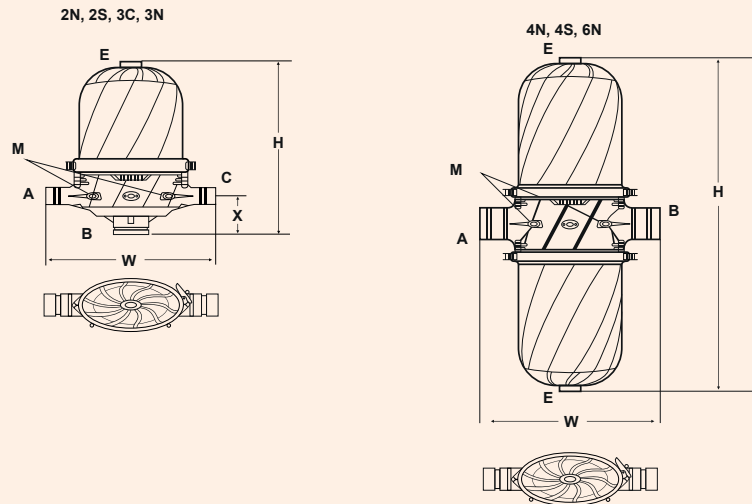

Connection	Model	Connection			Dimensions					
		A	B	C	H		W		X	
					mm	in	mm	in	mm	in
2"	2NR	BSP	BSP	BSP	595	23.4	310	12.2	133	5.2
	2NA	NPT	NPT	NPT						
	2NV	GROOVED	GROOVED	BSP						
	2NW	GROOVED	BSP	GROOVED						
2"Super	2SR	BSP	BSP	BSP	720	28.3	310	12.2	133	5.2
	2SA	NPT	NPT	NPT						
	2SV	GROOVED	GROOVED	BSP						
	2SW	GROOVED	BSP	GROOVED						
3"C	3CR	BSP	BSP	BSP	610	24	336	13.2	147	5.8
	3CA	NPT	NPT	NPT						
	3CV	GROOVED	GROOVED	BSP						
	3CW	GROOVED	BSP	GROOVED						
3"	3NR	BSP	BSP	BSP	735	28.9	336	13.2	147	5.8
	3NA	NPT	NPT	NPT						
	3NV	GROOVED	GROOVED	BSP						
	3NW	GROOVED	BSP	GROOVED						
4"	4NL	GROOVED	GROOVED	-	950	37.4	341	13.4	-	-
	4NB	FLANGE	FLANGE	-						
4"Super	4SL	GROOVED	GROOVED	-	1200	47.2	341	13.4	-	-
	4SB	FLANGE	FLANGE	-						
6"	6NB	FLANGE	FLANGE	-	1200	47.2	531	20.9	-	-

Function

The wastewater is then pumped from collection tank via Strainer system. The strainer is another non-electric physical filtration system composed of rings and mesh of 450 microns in size. Following are the main functions of strainer:

The sewage passing through it becomes free from silt. It not only removes TSS but it also supports in removing BOD & COD.

The overall removal of TSS is about 70–90 per cent and BOD, COD reduction by 10–15 per cent.

The strainer is equipped with self-cleansing system or can be cleaned manually.

Straining supports in non-clogging of vermi or bio-filtration sewage treatment system.

Components



Strainer

- To separate slit content from the wastewater
- To collect small particles up to 450 microns like small solid waste particle.

Process Description

Equipment

Vermi or Bio-filter Bed

Illustration



Function

The sprinkled wastewater flows through the bed of bio-filter. The bed consists of two different layers. **First layer is of five stacks of perforated food grade plastic crates filled with earthworm (e.fetida) and popular wooden chips.** Each stacks takes a depth of 0.2m. The function of first layer are:

Earthworm (e.fetida) promotes the growth of beneficial decomposer bacteria in wastewater and acts as an aerator, grinder, crusher, chemical degrader and a biological stimulator. It also hosts millions of decomposer microbes in their gut and excreta called vermicast. The nutrients N and P are further used by the microbes for multiplication and enhanced action. The number of bacteria and actinomycetes contained in the ingested material increased up to 1000-fold while passing through the gut. A population of worms numbering about 15000 will in turn fosters a microbial population of billions of millions. The two processes-microbial processes and vermin-process simultaneously work in the Biofilter system.

Nitrogen and phosphorous removal observed 90–97 per cent. BOD & COD reduction observed 90–95 per cent.

The second layer consists of three batches of stones and pebbles of different sizes. The major function of the second layer are:

This helps in supporting fine TSS (20–30 per cent) removal.

The microorganism contributing in organic matter removal (BOD/COD 10–15 per cent).

Area required is 0.75 m² per m³ or 1 KLD. 1KLD requires 15 nos. of crates. Each crate contains 10 kg organic wood and worms

Components



Plastic Orate



Earthworm (e.fetida)

Popular Wooden Chips



Stone Pebbles

Crushed Stones with Pebbles

First Layer

- Earthworm (e.fetida) acts as media to host millions of microorganisms, which help in rapid degradation of the organic matter and nutrients present in the wastewater.

Second Layer

- The stone media and sand provides good layer for physical filtration and also provides breeding ground for attached growth system of microorganism.

Process Description

Equipment

Advanced Oxidation

Illustration

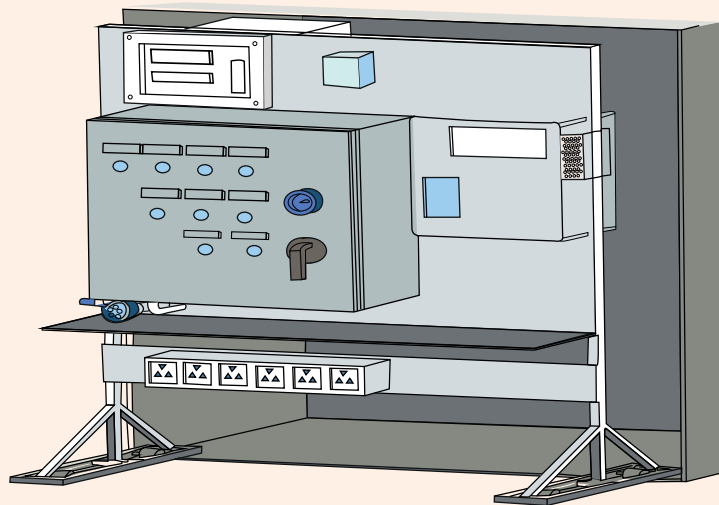

Function

Use of **ozone eliminates the precursors** that supports in formation of THM and other carcinogenic compounds. (least/negligible formation of THMs):

Ozone (300 times reactive) completely **dominates the microbial growth** by rupturing the cell wall whereas the chlorine functions on selective microbial using ingestion mechanism which reduces its potential by 300 times as compared to ozone.

Effective on **all kinds of bacteria and viruses and parasites**

Ozone solves multiple Water Quality Issues (Recalcitrant COD, colour, odour, improved floc etc.)

No chemical Storage (no safety issues reg. tanks, leakage etc.) 5.Short Contact Time (minutes versus hours) as compared to chlorine.

6.Environmentally safe since produced from Oxygen and decomposes back to Oxygen.

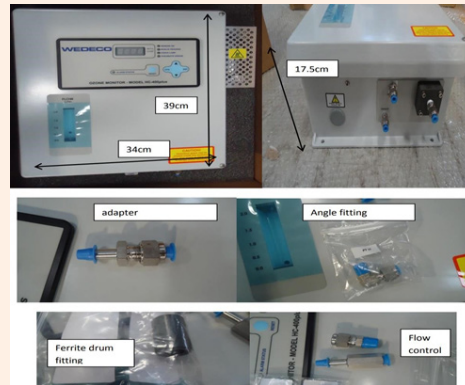

TECHNICAL DATA	
POWER CONSUMPTION	3KVA
OPERATING PRESSURE	0.5bar g
GAS FLOW	0.08m ³ /h
SUPPLY VOLTAGE	230V
FREQUENCY	50Hz
CURRENT	13,1 A
WIDTH	600mm
DEPTH	210mm
HEIGHT	600mm
WEIGHT	35Kg
Ambient temperature for transport and storage	-20 to 60°C

Components

P & I Diagram

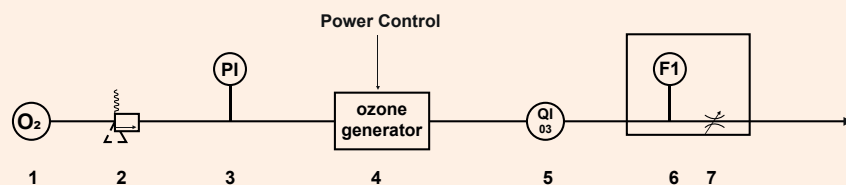

- Oxygen Source (0,7 to 7,0 bar)
- Pressure Regulator
- Pressure Gauge (0 to 1,6 bar)
- Ozone Analyzer (0 to 300 go3/m3)-optional-
- Flow Meter (10 to 110 l/h)
- Throttle Valve

8.4 Financial Details

This technology is found suitable for liquid waste management. The details for cost of construction and installation, area and power requirement, etc. are mentioned below:

Sr. No.	Technical & Financial Details	
1.	Technology Name	Waste Stabalization Pond
2.	Technical Details	
	a. Area Requirement	Area Requirement: 5 Square Metre For 10 KLD Area Requirement: 130 Square Metre For 100 KLD
	b. Power Requirement	For 1 KLD Power requirement: 28.8 KW For 100 KLD Power requirement: 60 KW
	c. Water Requirement	NR
	d. Manpower Requirement (Skilled, Semi-skilled, Unskilled)	Unskilled
3.	Cost Information	
	a. CapEx (Rs. lakhs)	Rs. 9,90,000/- FOR 10 KLD Rs. 26,00,000/- FOR 100 KLD
	b. OpEx (Rs. lakhs)	Rs. 2,40,000/- FOR 10 KLD (Per Month or Annum) <u>Rs. 4,80,000/- FOR 50 KLD (Per Month or Annum)</u>



OTHER TECHNOLOGIES





COMMUNITY HORIZONTAL FILTER SYSTEM

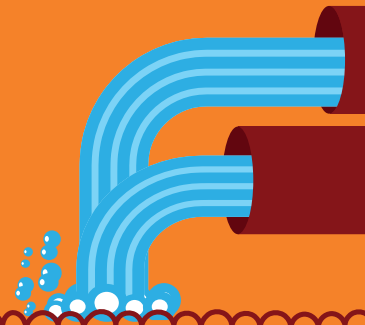

9.1 Introduction

The community horizontal filter system is one of the simplest greywater management technique capable of treating community greywater generated in rural areas. This allows the greywater to pass horizontally through the series of chambers, filter media and achieve the treatment of greywater. The treated water can be used for irrigation, agriculture, construction other than drinking purpose.



Figure 5: Community Horizontal Filter System

9.2 Feasibility

Geographic Requirement

Community Horizontal Filter System can be installed in any terrain and all built environments, wherever the greywater needs to be treated and to be reused for non-potable purposes. These Horizontal filters are more suitable in areas where groundwater table is high and permeability of the soil is low.

Appropriateness of Technology

Community Horizontal Gravel Filter significantly contribute to the greywater treatment and reuse in the rural areas of the country. The major appropriateness of this system is highlighted below:

*The filter bed is suitable to treat approximately 1 to 1.5 KLD of greywater which is generated from hard core rural areas with an allowable microbial load of BOD less than 50 mg/l, COD less than 100 mg/l and TDS less than 700 mg/l

9.3 Technical Details

Design and Process Description

The community horizontal filter system works on the principle of treatment of greywater based on filtration and microbial actions on the effluent in the constructed wetland filter bed.

The following are the design components of community horizontal filter:

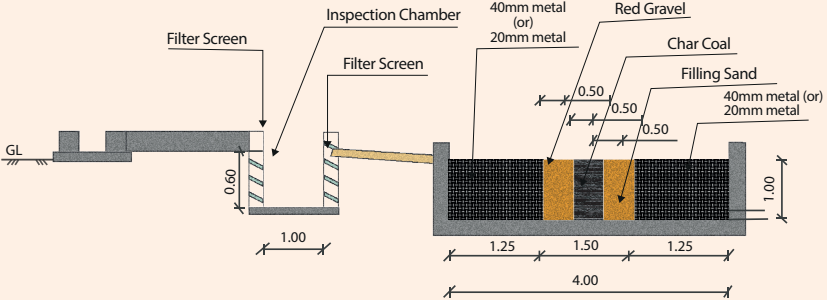
<p>Equipment</p>	<p>Horizontal Soak Pit</p>  <p><i>Cross Section For Horizontal Soak Pit</i></p>
<p>Illustration</p>	<p>The functional aspects of different layers of filter bed are:</p>
<p>Function</p>	<p>Coarse material helps to remove floating or suspended particles. This provides space for roots to grow. The supply of oxygen from roots facilitates growth of aerobic bacteria which helps in decomposition of organic matter.</p> <p>Red gravel helps to remove finer suspended particles. The roots of plants extend through this layer. Both aerobic and anaerobic bacteria are present in the zone act upon the suspended and dissolved organic matter.</p> <p>Charcoal removes organic and trace metals (toxic metals)</p> <p>Sand removes finer and left out particles and provide clear treated water</p>

Components

*Bye pass arrangement for diverting the storm water is also part of the filter bed to prevent choking of filter bed due to excess water load in rainy season.

*The atmospheric oxygen flows inside the filter bed through the coarse filter bed and oxygen gets released through the roots of the plants symbiotically help each other in colonizing the microbes as well as plant health thus resulting in treated greywater through the effluent pipe.

Major components of the horizontal filter bed for 1 to 1.5 KLD capacity are:

Filter bed: 4m x 3m size filter bed to be designed for the rural characteristics greywater discharge which has BOD less than 50

Filter bed with the comprises of the following components:

Sl. no	Component of filter bed	Size
	Coarse material	20mm /40 mm metals with a filling size of 4.00m X 1.25 m X 1.00 m
	Red gravel	Size of 4.00 mx 0.5x 1.0m
	Activated charcoal	Size 4.00 mx 0.5x 1.0 m
	Fine sand	Size of 4.00 m x 0.5 mx 1.0 m

Inspection chamber: size 1mx 1mX0.6m to screen particles of size more than 20 mm which also allows uniform flow into the filter bed

9.4 Financial Details

This technology is found suitable for greywater management at cluster levels. The details for cost of construction & installation, Area & Power requirement etc. are mentioned below:

Sr. No.	Technical & Financial Details	
1.	Technology Name	Community Horizontal Filter System
2.	Technical Details	
	a. Area Requirement	4.46m * 3.46m * 1.45m (L*B*H)
	b. Power Requirement	0 NR
	c. Water Requirement	0 NR
	d. Manpower Requirement (Skilled, Semi-skilled, Unskilled)	Unskilled
3.	Cost Information	
	a. CapEx (Rs. lakhs)	Rs. 1,52000/-
	b. OpEx (Rs. lakhs)	Rs. 10,000/- PER YEAR

10

COMMUNITY VERTICAL SOAK PIT

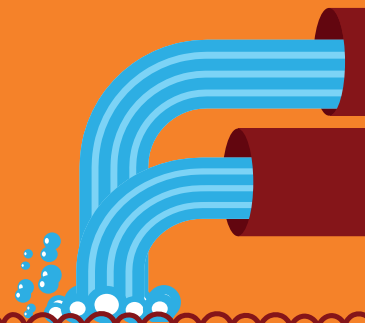

10.1 Introduction

The community vertical filter system is an extended version of a household soak pit where multiple houses can be connected to a single soak pit. The number of houses to be connected should be calculated based on greywater discharged from each house and space available for a community soak pit. Greywater from houses (wastewater from kitchen, bathing and washing area) pass through the dug-out pit that is filled with graded stones and gravels. The stones increase the surface area over which biological and chemical action take place. The treated water is recharged into the ground and helps in maintaining the groundwater table.



10.2 Feasibility

Geographic Requirement

Community vertical soak pits are best suited for soil with good absorptive properties. The performance of a soak pit depends on the permeability of the soil, e.g., sand has very high percolates on working very efficiently, while black cotton soil absorbs less water and therefore the soak pit will work with very low efficiency where it is present. Similarly, clayey soils and rocky terrain are not suitable for soak pits as their permeability is low. In case such a system is not available, it is recommended that a field test for percolation be carried out.

Appropriateness of Technology

Community vertical filter system are more suitable in areas where the groundwater table is low and permeability of the soil is high. The major appropriateness of this system are highlighted below:

*The filter bed is suitable to treat approximately 2.5 to 3 KLD of greywater which is generated from hard core rural areas with an allowable microbial load of BOD less than 50 mg/l, COD less than 100 mg/l and TDS less than 700 mg/l

10.3 Technical Details

Design and Process Description

The community vertical filter system works on the principle of treatment of greywater based on filtration and microbial actions on the effluent in the constructed wetland filter bed.

The following are the design components of community vertical filter:

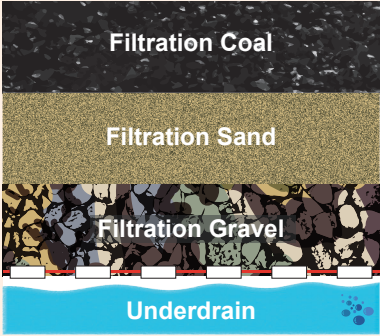
Equipment	Community Vertical Soak Pit
Illustration	 <p style="text-align: center;">DUAL - MEDIA</p> <p style="text-align: center;"><i>Cross Section for Horizontal Soak Pit</i></p>
Function	<p>The functional aspects of different layers of filter bed are:</p> <p>Coarse material helps to remove floating or suspended particles. This provides space for roots to grow. The supply of oxygen from roots facilitates growth of aerobic bacteria which helps in decomposition of organic matter.</p> <p>Red gravel helps to remove finer suspended particles. The roots of plants extend through this layer. Both aerobic and anaerobic bacteria are present in the zone act upon the suspended and dissolved organic matter.</p> <p>Charcoal removes organic and trace metals (toxic metals)</p> <p>Sand removes finer and left out particles and provide clear treated water</p>

*Bye pass arrangement for diverting the storm water is also part of the filter bed to prevent choking of filter bed due to excess water load in rainy season.

*The atmospheric oxygen flows inside the filter bed through the coarse filter bed and oxygen gets released through the roots of the plants symbiotically help each other in colonizing the microbes as well as plant health thus resulting in treated greywater through the effluent pipe.

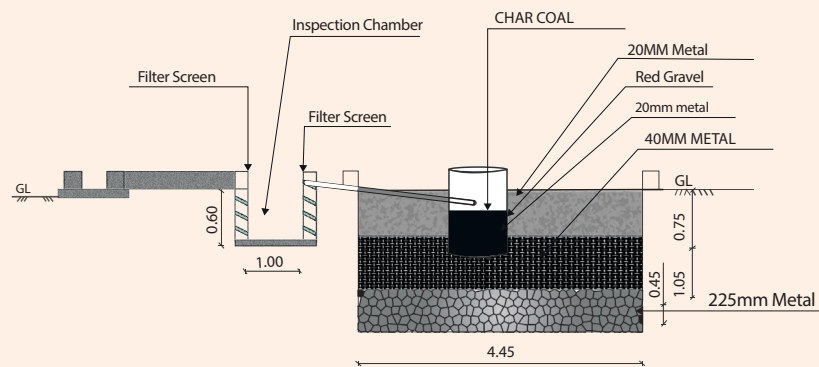

Cross Section for Vertical Soak Pit

Components

Major components of the vertical filter bed for 2.5 to 3 KLD capacity are:

Filter bed: 4.45 m x 4.45 m size filter bed to be designed for the rural characteristics greywater discharge which has BOD less than 50

Filter bed with the comprises of the following components:

Component of filter bed	Size
Coarse material	225mm metals to a filling size of 4.45 X 4.45 m X 0.45 m 40mm metals to a size of 4.45 m X 4.45 m x 1.05 m 20 metals to a size of 4.45 m X 4.45 m X 0.75m
Red gravel	Size of 0.30 mm
Activated charcoal	Size of 0.30 mm
Sand	20 mm metal size of 0.30 m

Inspection chamber: size 1mx 1mX0.6m to screen particles of size more than 20 mm which also allows uniform flow into the filter bed

10.4 Financial Details

This technology is found suitable for greywater management at cluster levels and also for recharging the groundwater table. The details for cost of construction & installation, Area & Power requirement etc. are mentioned below:

Sr. No.	Technical & Financial Details	
1.	Technology Name	Community Vertical Filter System
2.	Technical Details	
	a. Area Requirement	4.45m * 2.25m (Diameter*Depth)
	b. Power Requirement	NR
	c. Water Requirement	NR
	d. Manpower Requirement (Skilled, Semi-skilled, Unskilled)	Unskilled
3.	Cost Information	
	a. CapEx ((INR lakhs)	Rs. 1,27,000/-
	b. OpEx (INR lakhs)	Rs. 10,000/- PER YEAR



DECISION MATRIX FOR ADOPTION OF GWM TECHNOLOGY



HIGH WATER TABLE AREAS

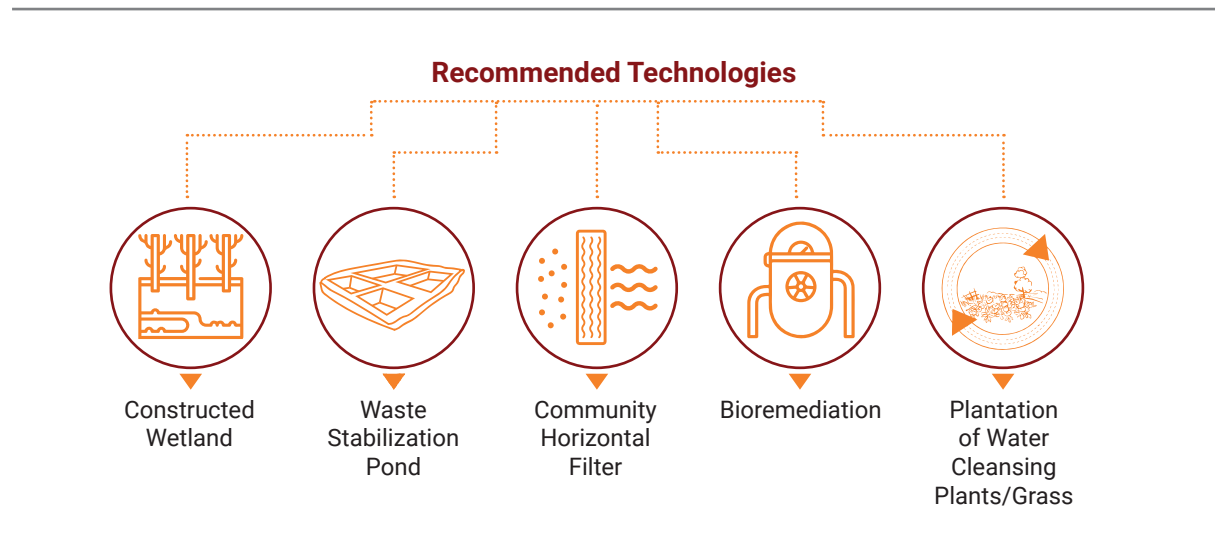

For High Water Table Areas

Availability of Land (High)		Availability of Land (Moderate)		Availability of Land (Low)	
Quantum of Flow		Quantum of Flow		Quantum of Flow	
High	Waste Stabilization Pond	High	Combination of Constructed Wetland and WSP	High	Bioremediation
Moderate	Constructed Wetland	Moderate	Integrated Community Horizontal Filter	Moderate	Plantation of Water Purification Plants with Bar Screens/Bunds
Low	Community Horizontal Filter	Low	Plantation of Water Purification Plants	Low	Plantation of Water Purification Plants

Sr. No	Quantum of Flow	Land Availability	Preferred Technology	Details of the Intervention	Reuse/ Recharge
1	High	High	Waste Stabilization Pond	Lining of RCC in the presence of water proofing admixtures to avoid seepages into the ground.	Reuse
2	Moderate		Constructed Wetland	Horizontal flow Constructed wetland should be adopted	Reuse
3	Low		Community Horizontal filter		Recharge
4	High	Moderate	Combination of WSP and Constructed Wetland	Here the Nallah will be modified into constructed wetland	Recharge
5	Moderate		Integrated Community Horizontal Filter	As per the availability of land different units of community horizontal filter will be installed	Reuse
6	Low		Plantation of Water Purification Plants	Plantation of water purification plants/grass such as canna, phragmites etc. shall be install on the layering of silter media	Recharge
7	High	Low	Bioremediation	Dosing of Bioremediation bacteria should be provided in regular interval by installing dosing systems	Recharge
8	Moderate		Plantation of Water Purification Plants along with Installation of Manual Bar Screen Chamber/Sand Bunds	Plantation of water cleansing plants/grass such as canna,phargmites etc. along with installation of bar screen and sand bunds to collect the solid waste and increase the retention time.	Reuse + Recharge
9	Low		Plantation of Water Purification Plants	Plantation of water purification plants/grass such as canna, phragmites etc. shall be install on the layering of filter media	Recharge

LOW WATER TABLE AREAS

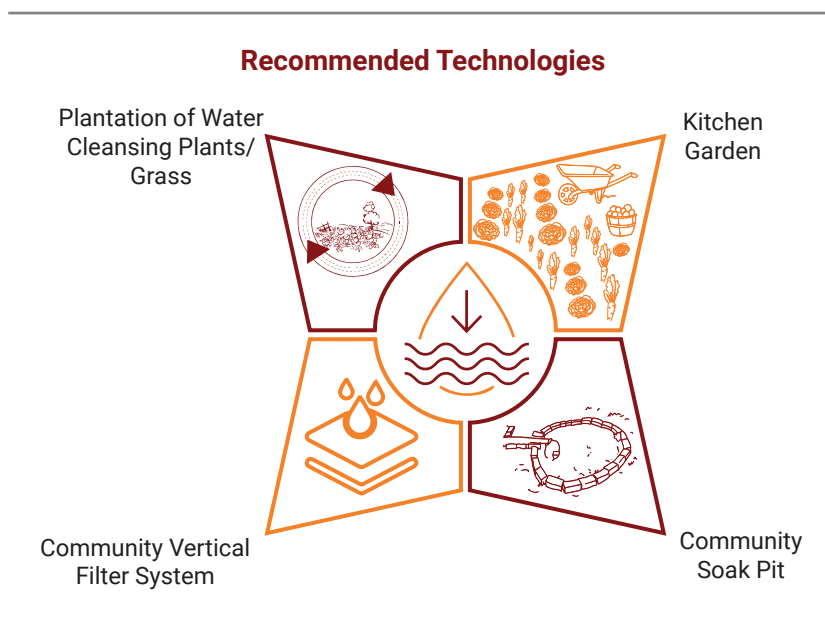

For Low Water Table Areas

Availability of Land (High)		Availability of Land (Moderate)		Availability of Land (Low)	
Quantum of Flow		Quantum of Flow		Quantum of Flow	
High	Kitchen Gardens	High	Intergrated Community Horizontal Filter	High	Community Vertical Filter along with Plantation on Sides of the Drain
Moderate	Community Vertical Filter	Moderate	Community Soak Pit	Moderate	Plantation of Water Purification Plants with Bar Screens/Bunds
Low	Community Soak Pit	Low	Plantation of Long Rooted Water Cleansing Plants	Low	Plantation of Water Cleansing Plants

Sr. no.	Quantum of Flow	Land Availability	Preferred Technology	Details of Intervention	Reuse/ Recharge
1	High	High	Kitchen Gardens	Individual household kitchen gardens should be adopted	Reuse
2	Moderate		Community Vertical Filter System	Vertical flow will help in groundwater recharge	Recharge
3	Low		Community Soak Pit	Different units of community soak pit shall be installed according to the cluster of households	Recharge
4	High	Moderate	Integrated Community Horizontal Filter	As per the availability of land different units of community vertical filter will be installed	Recharge
5	Moderate		Community Soak Pit	Different units of community soak pit shall be installed according to the cluster of households	Recharge
6	Low		Plantation of Long Rooted Water Cleansing Plants	Plantation of long rooted water cleansing such as plants/grass such as canna, phragmites etc. Shall be install on the layering of filter media	Recharge
7	High	Low	Combination of Community Vertical Filter along with Plantation on Sides of the Drain	Installation of community vertical filter as per land availability along with plantation of water cleansing plants on sides of the nallah.	Recharge
8	Moderate		Plantation of Water Cleansing Plants along with Installation of Manual Bar Screen Chamber/Sand Bunds	Plantation of water cleansing plants/grass such as canna, phragmitesetc along with installation of bar screen and sand bunds to collect the solid waste and increase the retention time.	Reuse + Recharge
9	Low		Plantation of Water Cleansing Plants.	Plantation of water cleansing plants/grass such as canna, phragmitesetc shall be install on the layering of filter media	Recharge

VILLAGES WITH POPULATION MORE THAN 5000

In villages with population of more than 5000, Rs. 660 per capita funding provision is provided according to Swachh Bharat Mission(Grameen) (SBM[G]) Phase II operational guidelines.

Recommended Technologies

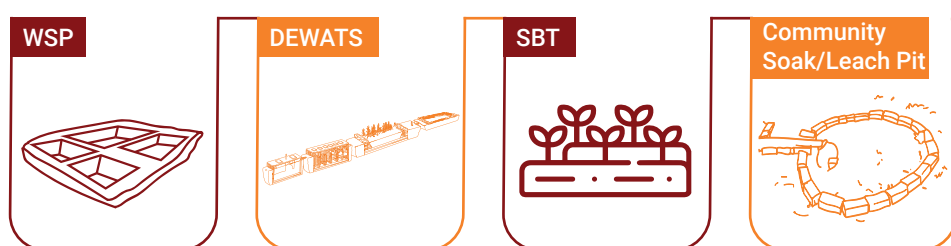

For Population More than 5000

Availability of Land (High)		Availability of Land (Moderate)		Availability of Land (Low)	
Quantum of Flow		Quantum of Flow		Quantum of Flow	
High	Waste Stabilization Pond	High	Decentralized Waste Water Treatment System	High	Decentralized Wastewater Treatment System
Moderate	Decentralized Waste Water Treatment System	Moderate	Community Horizontal Filter	Moderate	Community Horizontal Filter
Low	Community Soak/Leach Pit	Low	Community Soak/Leach Pit	Low	Community Soak/Leach Pit

Sr. no.	Land Availability	Quantum of Flow	Preferred Technology	Details of the Intervention	Reuse/ Recharge
1	High	High	Waste Stabilization Pond	Installation of wsp at the collection point of the greywater of the village	Reuse
2	Moderate		Decentralized Wastewater Treatment System	Diverting the greywater at a common place and treatment through installation of dewats	Reuse + Recharge
3	Low		Community Soak/ Leach Pit	Identification of cluster of household and connecting them with community soak/ leach pit system will be adopted	Recharge
4	High		Decentralized Wastewater Treatment System	Diverting the greywater at a common place and treatment through installation of dewats	Reuse + Recharge
5	Moderate	Moderate	Community Horizontal Filter System	Identification of cluster of household and connecting them with community horizontal	Reuse
6	Low		Community Soak/ Leach Pit	Identification of cluster of household and connecting them with community soak/ leach pit system will be adopted	Recharge
7	High		Decentralized Wastewater Treatment System	Diverting the greywater at a common place and treatment through installation of dewats	Reuse + Recharge
8	Moderate	Low	Community Horizontal Filter System	Identification of cluster of household and connecting them with community horizontal	Reuse
9	Low		Community Soak/ Leach Pit	Identification of cluster of household and connecting them with community soak/ leach pit system will be adopted	Recharge

VILLAGES WITH POPULATION LESS THAN 5000

In villages with population less than 5000, Rs. 280 per capita funding provision is provided according to SBM(G) Phase II operational guidelines.

Recommended Technologies

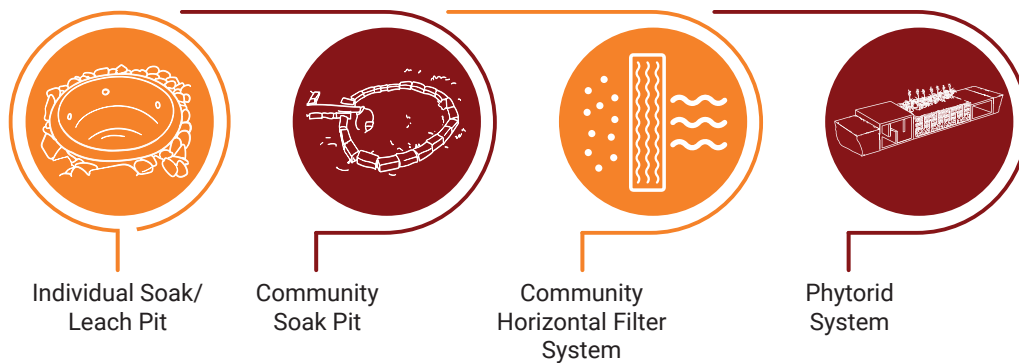

For Population Less Than 5000

Availability of land (High)		Availability of land (Moderate)		Availability of land (Low)	
Quantum of Flow		Quantum of Flow		Quantum of Flow	
High	Individual Leach Pit	High	Individual Soak Pit	High	Individual Leach Pit
Moderate	Community Horizontal Filter	Moderate	Community Horizontal Filter	Moderate	Community Soak/Leach Pit
Low	Community Soak/Leach Pit	Low	Community Soak/Leach Pit	Low	Community Soak/Leach Pit

Sr. no.	Land Availability	Quantum of Flow	Preferred Technology	Details of the Intervention	Reuse/Recharge
1	High	High	Individual Leach Pit	Construction of individual household leach be suitable	Recharge
2	Moderate		Community Horizontal Filter System	Identification of cluster of household an connecting them with community system will be adopted	Reuse
3	Low		Community Soak/ Leach Pit	Identification of cluster of household an connecting them with community soak/leach system will be adopted	Recharge
4	High	Moderate	Individual Soak Pit	Construction of individual household leach be suitable	Recharge
5	Moderate		Community Horizontal Filter System	Identification of cluster of household an connecting them with community horizon system will be adopted	Reuse
6	Low		Community Soak/ Leach Pit	Identification of cluster of household and connecting them with community soak/leach system will be adopted	Recharge
7	High	Low	Individual Soak Pit	Construction of individual household leach be suitable	Recharge
8	Moderate		Community Soak/ Leach Pit	Identification of cluster of households an connecting them with community soak/leach system will be adopted	Recharge

CASE STUDIES





THAPPAR MODEL

The 2–3-acre pond situated on the outskirts of FagganMajra village in Patiala District of Punjab had been filthy for a long time. In the absence of desilting for an exceptionally long period, the capacity of the pond had decreased considerably, resulting in the back-flow of the water onto the streets, emitting a foul smell. The pond was a breeding ground for mosquitoes that increased the risk of vector borne diseases among the community, with harmful effects on the health of children studying in the primary school situated nearby. The village consisting of 352 households and a population of 2112 individuals had been the same for a long time.

To address the issue, the Sarpanch along with his Panchayat members actively sought a solution. They coordinated with the officials of the Department of Rural Development and Panchayats, who informed them that the village pond could be renovated by availing of MGNREGA and Pradhan Mantri Krishi Sinchai Yojna Schemes. They also recommended various technology options that can be adopted for the renovation of the pond.

Equipped with that information, the village Sarpanch and his Panchayat members organized a Gram Sabha during which the village community unanimously agreed to the action plan proposed by the Gram Panchayat, agreeing to implement the WSP technology adopted by the Thappar Institute of Engineering and Technology (Patiala) known as Thappar Model.

Thereafter, community mobilization and awareness activities were conducted in the village to make the community aware of the implementation process under which greywater, mixed with other waste generated from all the houses is taken to the pond for treatment.

The total cost of the project is Rs.18.61 lakhs and O&M cost will be 5 per cent of the estimated cost. The treated water will be used for irrigation purposes and the GP will generate revenue from it.

Benefits to the Community:

As the pond has been renovated under the MGNREGA scheme, it has generated employment for the village community. The renovation of the pond has beautified the village and ensured visual cleanliness. It will contribute to improvement of health. After the renovation, the capacity of water in the pond has increased. The treated water is used for irrigation purposes, reducing the dependence on bore wells.





SHEECHEWAL MODEL

The village of Baran in Patiala District of Punjab with a population of 3322 individuals has set up waste stabilization ponds (WSP) using the Sheechewal model to give new life to a pond and manage the wastewater that comes from all the 553 households.

Previously, the 2–3-acre pond situated in the heart of the village, and close to the historic Gurudwara Sahib was filthy, emitting such a foul smell that passersby found it an awful nuisance. In the absence of desilting for an exceptionally long period, the capacity of the pond had decreased considerably, resulting in back-flow of the water into the village roads. Moreover, it posed a potential health risk to the residents and a constant cause for complaint, leaving a poor impression on visitors.

Vexed with the situation, the village Sarpanch and his Panchayat members approached the officials of the Department of Rural Development and Panchayats, seeking a solution. The Department recommended the WSP technology developed by the Thapar Institute of Engineering and Technology (Patiala).

Baran village community which has in place a water supply scheme by which more than 80 per cent of the households have water while the remaining have their own sources of water such as submersible pumps unanimously agreed to go with the Thapar technology.

To begin with, community mobilization activities were conducted in the village to make the community aware about the implementation process under which wastewater generated from all the houses is taken to the pond for treatment through covered drainage system.

Moreover, the village pond has been renovated under MGNREGA scheme and in convergence with the Pradhan Mantri Krishi Sinchai Yojna (PMKSY). The total cost of the project is Rs.39.86 lakhs and O&M cost has been taken as 5 per cent of the estimated cost. The treated water will be used for the irrigation purposes and GP will generate revenue from it.

Benefits to the Community: As the pond has been renovated under MGNREGA scheme it has generated employment for the village community. The renovation of the pond has beautified the village, ensured visual cleanliness and has also contributed to improvement of health. After the renovation, the capacity of water in the pond has increased. The treated water is used for irrigation purposes, reducing the dependence on bore wells.

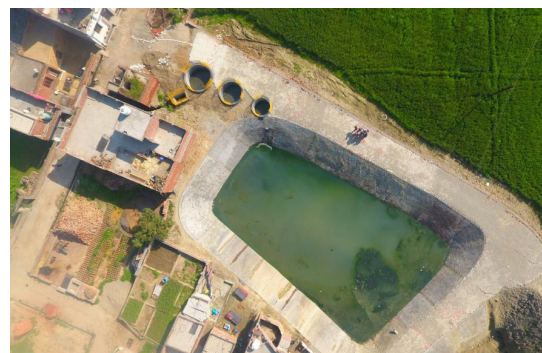



COMMUNITY HORIZONTAL FILTER

Previously, in the absence of any viable treatment process, greywater generated from the rural households was disposed of into the open drain, streets, vacant land or into water bodies that resulting in surface water contamination, land contamination and aggravated water-borne diseases.

To address the issue of greywater from kitchens and bathing areas of households that overflowed or stagnated, posing both environmental and public health risks, the village Panchayat of Pappankuzhi in Sriperumbudur Block of Kanchipuram District in Tamil Nadu has constructed both individual and community soak pits.

The Pappankuzhi village Panchayat that consisted of two habitations is home to 254 households and a population of 1016 individuals. It had 13 streets measuring about 900 metres each and two overhead tanks, each with a capacity of 30,000 litres.

With the support of the District administration as many as 93 of the 254 households were provided with individual soak pits under MGNREGA and 161 households were connected to the drainage channel constructed under MGNREGA.

Further, two horizontal soak pits with 18 cum and 16 cum were constructed at the disposal point and the filtered water was let into water bodies of PeriyaEri and RajanthagalEri.

The horizontal soak pits may be constructed at disposal point of drainage systems and is suitable for clusters with high groundwater table areas. The treated greywater can thereafter be used for agriculture purposes. These initiatives have contributed immensely to the visual cleanliness of the Panchayat, putting it on the road to ODF Plus.



COMMUNITY VERTICAL FILTER

KheriBir Singh village in Fatehgarh Sahib District of Punjab is a model village with an effective community-level greywater management system in place. This and other achievements of the village pertaining to infrastructural development and hygiene management are attributed to the energetic Sarpanch leading from the front.

For the past two years, the Sarpanch has worked with single-minded pursuit to make her village, the best in every field. With a relatively young and motivated five-member team, one of the first projects she spearheaded was to completely transform the drainage system. The open drains have caused untold agony for the village community for several years now, serving as a breeding ground for mosquitoes and other vector borne diseases such as malaria and dengue that have plagued the village. Now, the closed drains ensure that rainwater does not get mixed up with the wastewater, enhancing the hygiene of our village.

A recent initiative has been the creation of a greywater management system to improve groundwater levels which have been a consistent cause of concern. Inspired by the successful interventions of Tamil Nadu in this sector, a community soak pit was constructed for the first time in Punjab in this Fatehgarh Sahib village. The soak pit has porous walled chambers that allow greywater to seep into the ground. The liquid waste from households is channelled into this soak pit and allows a simple yet cost-effective way of replenishing the groundwater table.

The work was implemented under MGNREGA in 2020-21 at a cost of Rs 1.22 lakhs.

At the outset, a pit measuring 16 ft X 8 ft X 9 ft was made and an inspection chamber measuring 4ftX4ftX3ft was constructed nearby. The inspection chamber serves as the first point for collection of greywater. Thereafter, a PVC pipe of 6-inch diameter was laid down from the inspection chamber to the soak pit. It is here that water is filtered, facilitating the recharge of groundwater. Through a process of sedimentation enabled by three layers consisting of boulder stone, red gravel and aggregate, the water is purified.

With this system taking care of all the greywater from 35 households in the village, stagnant water on the village paths is a thing of the past, reducing mosquito related diseases at the same time. Moreover, the vertical filter has aided the process of recharging groundwater levels.



The Sarpanch has also demonstrated to the village community the importance of rainwater harvesting system by installing rooftop rainwater harvesting system. To mobilize the community further, wall paintings and informational posters are installed in public spaces such as parks and gyms, to spread awareness on sanitation and water conservation.



WASTE STABILIZATION POND

Figure 1: Work in Progress of WSP at Sirsi Village

Sirsi village is located in block Nissing at Karnal District. There are about 360 households in the village having population of 2,400. The village faced a problem due to accumulation of water in low-lying areas, which further caused the nuisance of odour and mosquito breeding. The overall scenario of Sirsi was unhygienic and filthy. The village adopted a waste stabilization pond system for a liquid waste management. The project cost was around Rs. 30 lakhs. This not only solved issues related to liquid waste disposal, but also the GP obtained a source of revenue. It began to earn Rs. 0.50 lakh per annum, by leasing out the pond for fishing. The filthy site has now been converted into a picnic spot where the villagers can enjoy their leisure time.



Figure 2: Waste Stabilization Pond in Sirsi



CONSTRUCTED WETLAND

Figure 3: Work in Progress of WSP at Sirsi Village

Patora Gram Panchayat of Durg in Chhattisgarh had an adequate supply of water through a piped water supply system and 11 hand pumps. All the greywater generated in the village was collected and conveyed to a village pond through drains. However, previously there was no treatment facility at the tail end of the drains and hence, the discharge of untreated greywater into the pond contaminated its water. Over a period of time, the quality of pond water deteriorated to such an extent that it became unfit for irrigation as well. This became a grave problem and drew attention of the GP authorities. A gravel filter was installed at the entry point of the pond using GP funds. The filter was planted with canna indica, which removed nutrients and filtered the water prior to its entry into the pond. The cost for installation of the filter was Rs. 70,000.

The villagers doubted the capacity of the filter to treat water especially during rainy seasons, since the drains discharged a high volume of water which contained greywater as well as storm water. However, the gravel filter proved to be efficient in treating even the high volumes of water during the monsoons. As a result of the functioning of this efficient treatment unit, the overall quality of the village pond water has been improved and it can now be used for various non-potable purposes.

PHYTORID SYSTEM



Figure 4: Phytorid Plant Constructed at Dhorka, Haryana

Phytorid Plant Constructed at Bhilai

At Bhilai, a phytorid plant of 250 KLD was constructed in 2017. The system was connected by drains. The system was designed to handle a hydraulic load and organic load of 0.8 m³/d/m² and 3.4 g BOD₅/m²/h respectively.

The parameters of the treated water collected at the outlet had BOD less than 30 mg/l, TSS less than 50 mg/l and other parameters were well within the discharge norms as per standards. The treated water is used for washing vehicles and the rest for irrigation.

Phytorid Plant Constructed at Dhorka, Haryana

The plant, fed by drain water, having a capacity of 75 KLD, was constructed in 2019. The plant was designed for hydraulic loading of 0.8 m³/d/m² and organic loading of 3.4 g of BOD₅/m²/h. The parameters of the treated water collected at the outlet were as per discharge norms (BOD <30 mg/l, TSS <50 mg/l, etc.). The treated water is discharge into a drain connected to a waterbody.



Figure 5: Polishing Pond

Based on the technology of constructed wetlands, a plant for decentralized wastewater treatment has been developed by the Mentapally Gram Panchayat in Wanaparthy District of Telangana State. As per the 2011 census, village Mentapally had a population of 1201 distributed over 267 households.

The execution of this liquid waste management intervention has been taken up by the District administration under MGNREGA and CSR funding by Rural Electrification Corporation Limited (RECL). The constructed wetlands present a feasible solution to the wastewater menace for small rural communities with limited resources and power supply. This technology can be more efficiently used with the facility of constructed cement drains wherein parallel treatment can be ensured within the drainage lines and at a later stage, the wastewater can be supplied to the wetlands to obtain clear water flows, further reuse and recycling.

Currently, the maintenance of this plant as well as of drainage lines is the responsibility of the Gram Panchayat. International Crops Research Institute for the Semi-Arid Tropics (ICRISAT) has proposed the development of 12 more such treatment units in the Districts of Rangareddy, Mahbubnagar, Wanaparthy and Sangareddy in Telangana.



Figure 6: Equalization Chamber and Aerobic Baffled Reactor



सत्यमेव जयते

Government of India
Ministry of Jal Shakti



ONE EARTH • ONE FAMILY • ONE FUTURE

